

DFF9000

DC Traction Protection Fundamental Frequency Detector



Our DFF9000 monitors the presence of 50/60 Hz fundamental frequency harmonics on DC railway electrical networks. Without this detection, the AC harmonics may disturb the power-line communication for signalisation, implying impact on the railway traffic.

Based on more than 40 years of experience in this field, our DFF9000 relay is part of our 9000 Series designed for monitoring and controlling railway systems.



- High resolution colour touch screen
- High accuracy acquisition
- Very high processing performance
- Fully configurable binary inputs and outputs

- Full **personalisation** according to customer needs
- Embedded web server
- IEC 61850 ed2 or Modbus servers
- 19" - 3U - 355 mm rack

OUR TRADEMARKS



FUNCTIONAL SCHEME

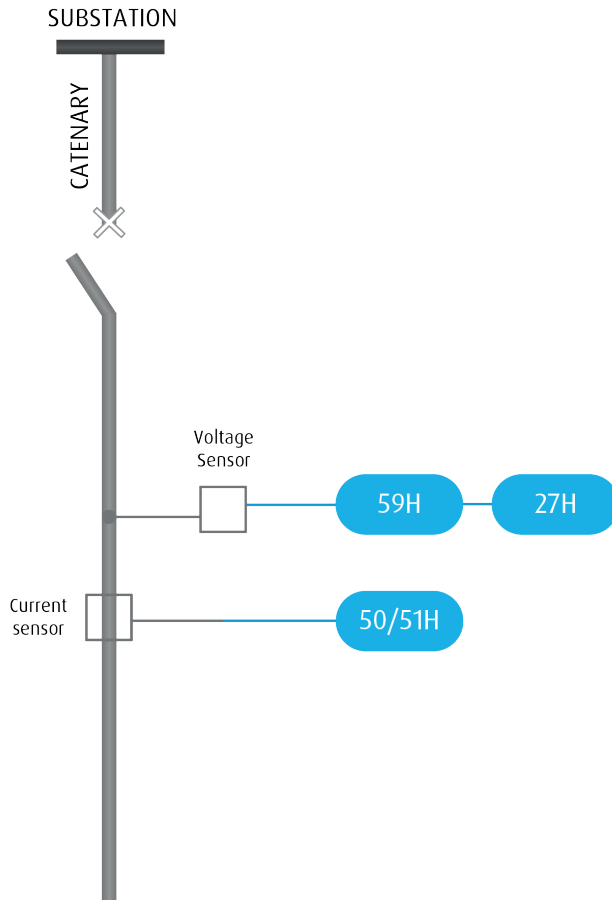

PROTECTION FUNCTIONS

- [50H] [51H] Harmonic overcurrent function
- [59H] Harmonic overvoltage function
- [27H] Harmonic undervoltage function

OPERATING FUNCTION

- [SC] Sensors monitoring

FULL PRODUCT PERSONALISATION

Our development team can fully customise our DFF9000 according to yours needs:

- changing for a higher sampling rate,
- recording specific events,
- new UI screen,
- new communication protocols like IEC 60870-5-104 or DNP3.0,
- other needs.

After customisation, you will also receive all the specific documentation (included an updated user manual) corresponding to your product.

