

NP950 Series

Protection, control, measuring and monitoring IEDs



The optimal management of electrical power systems is based on the reliability, availability and communication skills of protection, measurement and automation devices.

The NP950 Series devices offer a modular protection and control solution for applications requiring a large I/O capacity. Up to 11 optional I/O or communication cards are available for extensive monitoring and control applications.

The NP950 Series communicates using various protocols including the IEC 61850 substation standard.

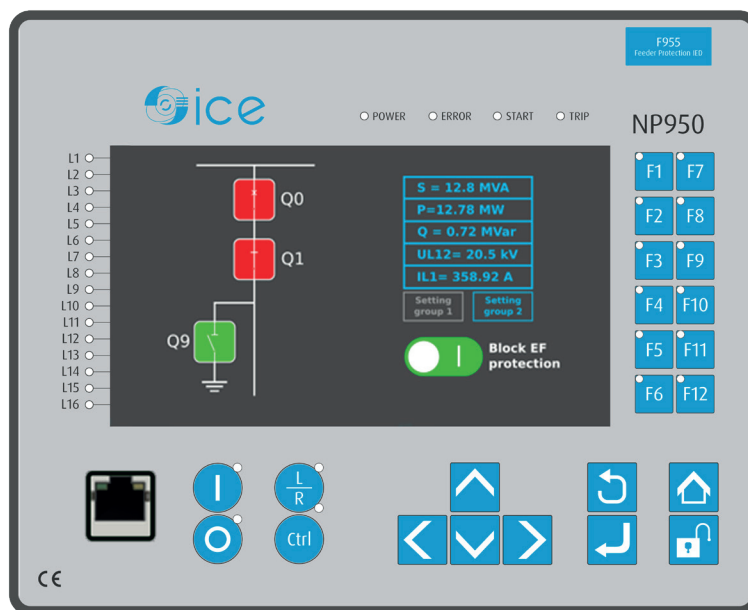

RE and Data Centre recommended.

- 3.2 kHz sampling rate
- Fully modular design
- IEC 61850 2nd Edition
- Large colourful configurable display

- Up to 11 additional module cards (depending on products)
- Arc flash compatible
- IEC 60255, RoHS and REACH compliance

OUR TRADEMARKS



TECHNIREL

Protection & Control
ice
Our energy at your service



NPF955 Feeder Protection IED



A large I/O capacity.

Double busbar control.

Optional automatic/manual voltage regulation and/or parallel voltage regulation (AVR).

Optional transformer module protections.

5-shot scheme-controlled auto-recloser.

The NPF955 feeder protection device offers a modular feeder protection and control solution for applications that require a large I/O capacity.

You can add up to total 11 optional modules (I/O and other type of modules) into the device for extensive monitoring and control applications. The NPF955 feeder protection device communicates using various protocols, including the IEC 61850 substation standard.

NPF955 Feeder Protection IED

PROTECTION

- Non-directional overcurrent ($I>$; 50/51)
- Non-directional earth fault ($IO>$; 50N/51N)
- Single-pole non-directional overcurrent ($IPW>$; 50/51)
- Directional overcurrent ($I_{dir}>$; 67)
- Directional earth fault ($IO_{dir}>$; 67N/32N)
- Intermittent earth fault ($IO_{int}>$; 67NT)
- Negative sequence overcurrent / Phase current reversal / Current unbalance ($I2>$; 46/46R/46L)
- Harmonic overcurrent ($I_h>$; 50H/51H/68H)
- Circuit breaker failure protection (CBFP; 50BF/52BF)
- High- and low-impedance restricted earth fault / Cable-end differential ($IO_d>$; 87N)
- Voltage-restrained overcurrent ($Iv>$; 51V)
- Overvoltage ($U>$; 59)
- Undervoltage ($U<$; 27)
- Neutral overvoltage ($U0>$; 59N)
- Sequence voltage ($U1/U2>/<$; 47/27P/59PN)
- Over- and underfrequency ($f>/<$; 810/81U)
- Rate-of-change of frequency ($df/dt>/<$; 81R)
- Power protection ($P,Q,S>/<$; 32)
- Overpower ($P>$; 32O)
- Underpower ($P<$; 32U)
- Reverse power (Pr ; 32R)
- Line thermal overload ($TF>$; 49F)
- Resistance temperature detectors (RTD)
- Transformer status monitoring (TST)
- Transformer thermal overload ($TT>$; 49T)
- Underimpedance ($Z<$; 21U)
- Underreactance ($X<$; 21/40)
- Volts-per-hertz overexcitation ($V/Hz>$; 24)
- Programmable stage ($PG>/<$; 99)
- Voltage memory
- Arc protection ($I_{Arc}>/IO_{Arc}>$; 50Arc/50Narc) (optional)

CONTROL

- Objects to control and monitor (OBJ): 10
- Single-pole object control and monitoring (OBJ5)
- Indicator objects to monitor (IND): 10
- Setting groups (SGS): 8
- Cold load pick-up (CLPU)
- Switch-on-to-fault (SOTF)
- Automatic voltage regulator (AVR; 90)
- Auto-recloser ($0 \rightarrow 1$; 79)
- Zero sequence recloser ($U0>$ RECL; 79N)
- Vector jump ($\Delta\phi$; 78)

MONITORING

- Current transformer supervision (CTS)
- Voltage transformer supervision (VTS; 60)
- Circuit breaker wear monitoring (CBW)
- Current total harmonic distortion (THD)
- Voltage total harmonic distortion (THD)
- Fault locator (21FL)
- Disturbance records: 100 (5s to 3.2 kHz sampling)
- Non-volatile event records: 15,000

HARDWARE

Standard features:

- Digital inputs: 3
- Digital outputs: 5
- Current inputs: 5
- Voltage inputs: 4
- Empty module slots: 11

Optional hardware modules:

- Digital input module: 8 inputs
- Digital output module: 5 outputs
- Milliampere I/O module: 4 outputs + 1 input
- Arc protection module: 4 sensors + 2 HSO + 1 BI
- External I/O modules

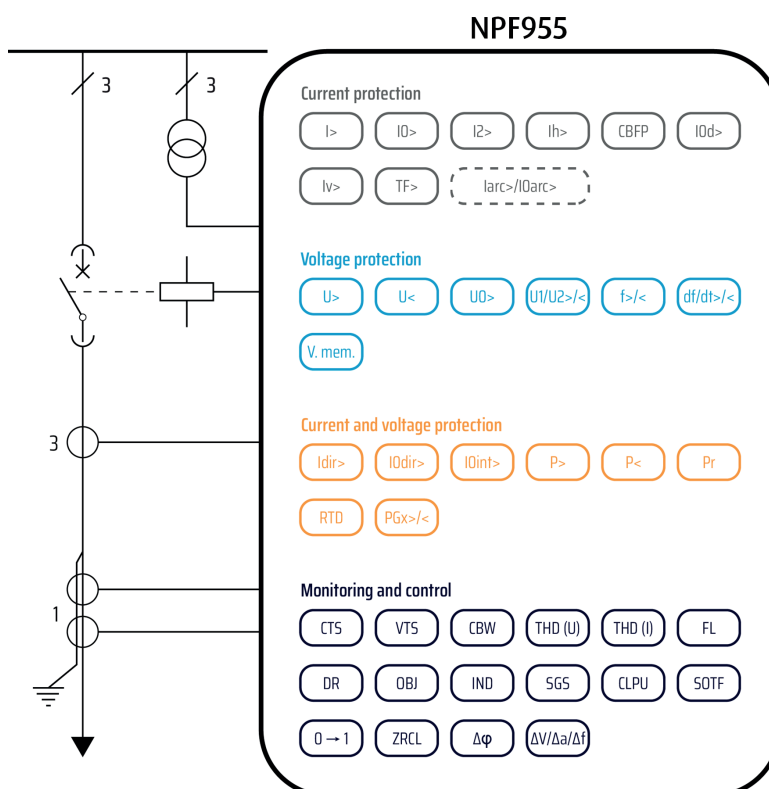



NPM955 Motor Protection IED



Powerful motor management with a large I/O capacity.

5 thermal models (time constant accurate).

Soft start protection begins at 6 Hz.

Star-delta started motor supervision.

Two-speed motor protection.

Asynchronous and synchronous motors.

The NPM955 motor protection device offers a modular protection and control solution for larger and more important motors that require a large I/O capacity.

You can add up to total 11 optional modules (I/O and other type of modules) into the device for extensive monitoring and control applications.

You can also connect up to 16 RTD signals for thermal alarms and trips. The NPM955 communicates using various protocols, including the IEC 61850 substation standard.

NPM955 Motor Protection IED

PROTECTION

- Non-directional overcurrent ($I>$; 50/51)
- Non-directional earth fault ($I0>$; 50N/51N)
- Directional overcurrent ($I_{dir}>$; 67)
- Directional earth fault ($I0_{dir}>$; 67N/32N)
- Negative sequence overcurrent / Phase current reversal / Current unbalance ($I2>$; 46/46R/46L)
- Harmonic overcurrent ($I_h>$; 50H/51H/68H)
- Circuit breaker failure protection (CBFP; 50BF/52BF)
- High- and low-impedance restricted earth fault / Cable-end differential ($I0d>$; 87N)
- Overvoltage ($U>$; 59)
- Undervoltage ($U<$; 27)
- Neutral overvoltage ($U0>$; 59N)
- Sequence voltage ($U1/U2>/<$; 47/27P/59PN)
- Over- and underfrequency ($f>/<$; 810/81U)
- Rate-of-change of frequency ($df/dt>/<$; 81R)
- Power protection ($P,Q,S>/<$; 32)
- Resistance temperature detectors (RTD)
- Motor status monitoring (MST)
- Machine thermal overload ($TM>$; 49M)
- Motor start / Locked rotor monitoring ($I_{st}>$; 48/14)
- Number of starts protection ($N>$; 66)
- Non-directional undercurrent ($I<$; 37)
- Locked rotor ($I_m>$; 51M)
- Power factor protection ($PF<$; 55)
- Programmable stage ($PG>/<$; 99)
- Arc protection ($I_{Arc}>/I0_{Arc}>$; 50Arc/50Narc) (optional)
- Voltage memory

CONTROL

- Objects to control and monitor (OBJ): 10
- Indicator objects to monitor (IND): 10
- Setting groups (SGS): 8

MONITORING

- Current transformer supervision (CTS)
- Voltage transformer supervision (VTS; 60)
- Circuit breaker wear monitoring (CBW)
- Current total harmonic distortion (THD)
- Voltage total harmonic distortion (THD)
- Disturbance records: 100 (5s to 3.2 kHz sampling)
- Non-volatile event records: 15,000

HARDWARE

Standard features:

- Digital inputs: 3
- Output relays: 5
- Current inputs: 5
- Voltage inputs: 4
- Empty module slots: 11

Optional hardware modules:

- Digital input module: 8 inputs
- Digital output module: 5 outputs
- Milliampere I/O module: 4 outputs + 1 input
- Arc protection module: 4 sensors + 2 HSO + 1 BI
- External I/O modules

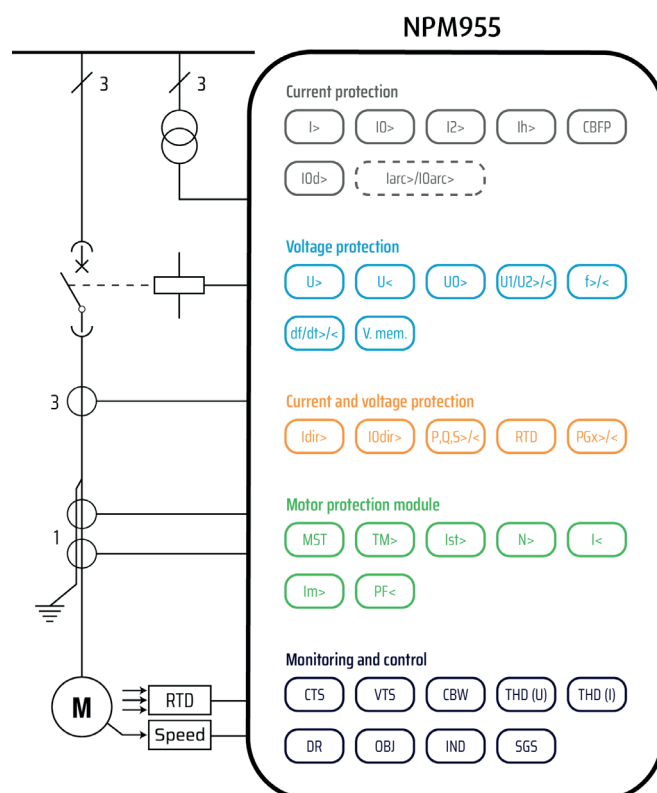



NPG957 Generator Protection IED



Complete synchronous machine protection.

Integrated differential protection.

The NPG957 generator protection device is well-suited for large machines that require complete generator protection and differential protection.

The device has an integrated automatic voltage regulator function. You can add up to total 9 optional modules (I/O and other type of modules) into the device for extensive monitoring and control applications.

You can also connect up to 16 RTD signals for thermal alarms and trips. The NPG957 communicates using various protocols, including the IEC 61850 substation standard.

NPG957 Generator Protection IED

PROTECTION

- Non-directional overcurrent ($I>$; 50/51)
- Non-directional earth fault ($I0>$; 50N/51N)
- Directional overcurrent ($I_{dir}>$; 67)
- Directional earth fault ($I0_{dir}>$; 67N/32N)
- Negative sequence overcurrent / Phase current reversal / Current unbalance ($I2>$; 46/46R/46L)
- Harmonic overcurrent ($I_h>$; 50H/51H/68H)
- Circuit breaker failure protection (CBFP; 50BF/52BF)
- High- and low-impedance restricted earth fault / Cable-end differential ($I0d>$; 87N)
- Voltage-restrained overcurrent ($Iv>$; 51V)
- Overvoltage ($U>$; 59)
- Undervoltage ($U<$; 27)
- Neutral overvoltage ($U0>$; 59N)
- Sequence voltage ($U1/U2>/<$; 47/27P/59PN)
- Over- and underfrequency ($f>/<$; 810/81U)
- Rate-of-change of frequency ($df/dt>/<$; 81R)
- Power protection ($P,Q,S>/<$; 32)
- Volts-per-hertz overexcitation ($V/Hz>$; 24)
- Underexcitation ($Q<$; 40)
- Underimpedance ($Z<$; 21U)
- Underreactance ($X<$; 21/40)
- Resistance temperature detectors (RTD)
- Machine thermal overload ($TM>$; 49M)
- Transformer/motor/generator differential ($I_{dx}>$; 87T/87M/87G)
- Power factor protection ($PF<$; 55)
- 100 % stator earth fault ($U03rd>$; 64S)
- Programmable stage ($PG>/<$; 99)
- Arc protection ($I_{Arc}>/I0_{Arc}>$; 50Arc/50Narc) (optional)
- Voltage memory

CONTROL

- Objects to control and monitor (OBJ): 10
- Indicator objects to monitor (IND): 10
- Setting groups (SGS): 8
- Vector jump ($\Delta\phi$; 78)

MONITORING

- Current transformer supervision (CTS) (2 instances)
- Voltage transformer supervision (VTS; 60)
- Circuit breaker wear monitoring (CBW)
- Current total harmonic distortion (THD)
- Voltage total harmonic distortion (THD)
- Disturbance records: 100 (5s to 3.2 kHz sampling)
- Non-volatile event records: 15,000

HARDWARE

Standard features:

- Digital inputs: 3
- Output relays: 5
- Current inputs: 10
- Voltage inputs: 4
- Empty module slots: 9

Optional hardware modules:

- Digital input module: 8 inputs
- Digital output module: 5 outputs
- Milliampere I/O module: 4 outputs + 1 input
- Arc protection module: 4 sensors + 2 HSO + 1 BI
- External I/O modules

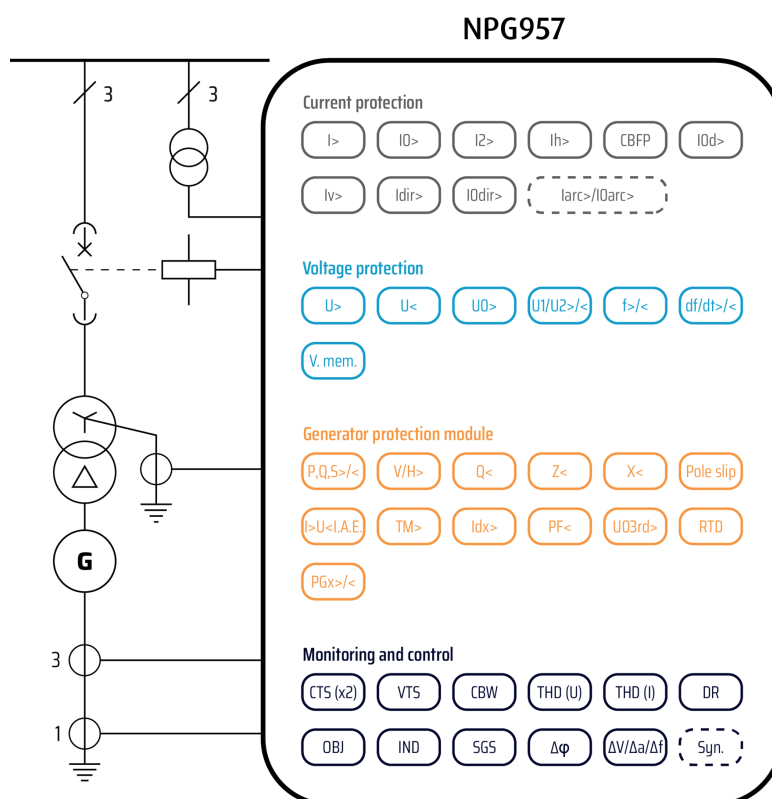



NPT957 Transformer Protection IED



A large I/O capacity.

Automatic/manual voltage regulation and/or parallel voltage regulation (AVR).

Complete transformer protection functionality.
2nd and 5th harmonic blocking.

Automatic verification of connection group and nominal value settings.

Overloading and through fault statistics for preventive maintenance.

The NPT957 is a transformer protection device with a differential protection function and an integrated automatic voltage regulator function.

The relay also provides complete current-based and voltage-based protection functions as well as full measurements.

You can add up to total 9 optional modules (I/O and other type of modules) into the device for extensive monitoring and control applications. The NPT957 communicates using various protocols, including the IEC 61850 substation standard.

NPT957 Transformer Protection IED

PROTECTION

- Non-directional overcurrent ($I>$; 50/51)
- Non-directional earth fault ($I0>$; 50N/51N)
- Directional overcurrent ($I_{dir}>$; 67)
- Directional earth fault ($I0_{dir}>$; 67N/32N)
- Negative sequence overcurrent/Phase current reversal/Current unbalance ($I2>$; 46/46R/46L)
- Harmonic overcurrent ($I_h>$; 50H/51H/68H)
- Circuit breaker failure protection (CBFP; 50BF/52BF)
- Overvoltage ($U>$; 59)
- Undervoltage ($U<$; 27)
- Neutral overvoltage ($U0>$; 59N)
- Sequence voltage ($U1/U2>/<$; 47/27P/59PN)
- Over- and underfrequency ($f>/<$; 810/81U)
- Rate-of-change of frequency ($df/dt>/<$; 81R)
- Power protection ($P,Q,S>/<$; 32)
- Volts-per-hertz overexcitation ($V/Hz>$; 24)
- Resistance temperature detectors (RTD)
- Transformer status monitoring (TRF)
- Transformer thermal overload ($TT>$; 49T)
- Transformer/motor/generator differential ($I_{dx}>$; 87T/87M/87G)
- Programmable stage ($PG>/<$; 99)
- Arc protection ($I_{Arc}>/I0_{Arc}>$; 50Arc/50Narc) (optional)
- Voltage memory

CONTROL

- Objects to control and monitor (OBJ): 10
- Indicator objects to monitor (IND): 10
- Setting groups (SGS): 8
- Switch-on-to-fault (SOTF)
- Vector jump ($\Delta\phi$; 78)
- Automatic voltage regulator (AVR; 90)

MONITORING

- Current transformer supervision (CTS) (2 instances)
- Voltage transformer supervision (VTS; 60)
- Circuit breaker wear monitoring (CBW)
- Current total harmonic distortion (THD)
- Voltage total harmonic distortion (THD)
- Fault locator (21FL)
- Disturbance records: 100 (5s to 3.2 kHz sampling)
- Non-volatile event records: 15,000

HARDWARE

Standard features:

- Digital inputs: 3
- Output relays: 5
- Current inputs: 10
- Voltage inputs: 4
- Empty module slots: 9

Optional hardware modules:

- Digital input module: 8 inputs
- Digital output module: 5 outputs
- Milliampere I/O module: 4 outputs + 1 input
- Arc protection module: 4 sensors + 2 HSO + 1 BI
- External I/O modules

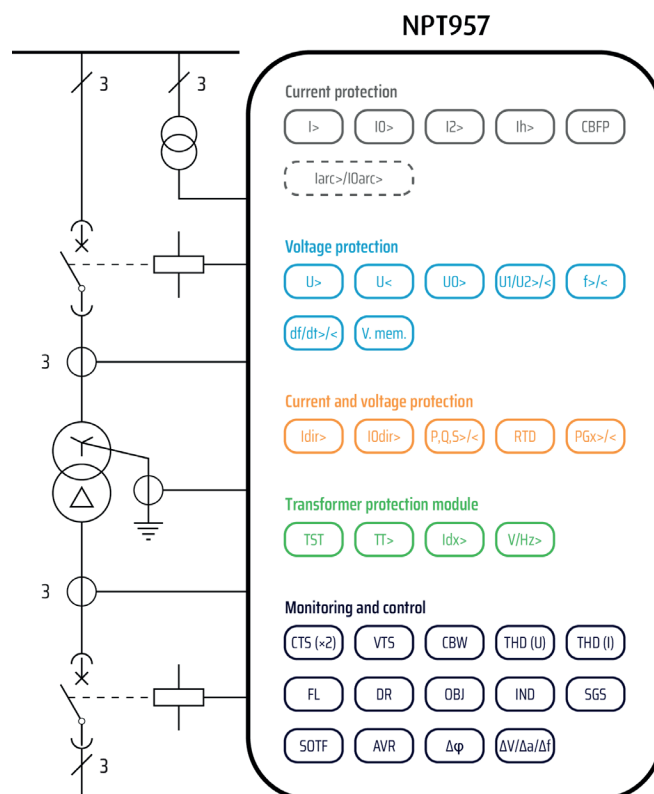



NPS954 Alarm and indication IED



Modern alarm sounding and a large I/O extension with IEC 61850 and GOOSE communication.

Control and status indication for 20 objects.

Full mimic diagram with busbar colouring.

Full-colour display for up to 128 alarms.

The NPS954 alarm and indication device can be applied to various substation tasks, extending the general I/O, sounding alarms, and control.

You can add up to total 14 optional modules (I/O and other type of modules) into the device, depending on the requirements of your application.

The logic programming is powerful and easy to use. It also further expands the device's application range towards more demanding control, alarm and indication needs.

The HMI is large and can be freely programmed, and provides a quick visualisation of the object as well as the status of alarms and events. NPS954 communicates using various protocols, including the IEC 61850 substation standard.

NPS954 Alarm and indication IED

ALARM, CONTROL, AND INDICATORS

- Objects to control and monitor (OBJ): 10
- Indicator objects to monitor (IND): 20
- Alarms to program: 128
- Setting groups (SGS): 8
- Disturbance records: 100 (5s to 3.2 kHz sampling)
- Non-volatile event records: 15,000

HARDWARE

Standard features:

- Digital inputs: 3
- Output relays: 5
- Empty module slots: 14

Optional hardware modules (up to 14):

- Digital input module: 8 inputs
- Digital output module: 5 outputs
- Milliampere I/O module: 4 outputs + 1 input
- Arc protection module: 4 sensors + 2 HSO + 1 BI
- External I/O modules

CHARACTERISTICS

MEASUREMENTS

- Phase, sequence and residual currents (IL1, IL2, IL3, I01, I02)
- Phase, sequence and residual voltages (UL1, UL2, UL3, UL12, UL23, UL31, U0)
- Frequency (f)
- Power (P, Q, S, cos φ) and energy (E+, E-, Eq+, Eq-)
- Power and energy measurement accuracy 0.5

COMMUNICATION

Standard inputs:

- 1 port with RJ-45 Ethernet 100 MB (front)
- 1 port with RJ-45 Ethernet 100 MB (rear, COM A)
- 1 port with RS-485 (rear, COM B)

Optional communication modules:

- 2 × RJ-45 Ethernet (100 MB/s) + IRIG-B input
- 2 × ST Ethernet (100 MB/s) + IRIG-B input
- 2 × LC Ethernet (100 MB/s, PRP/HSR)
- RS-232 serial fibre (PP/PG/GP/PP)

Protocols:

- IEC 61850 (1st and 2nd Edition)
- IEC 60870-5-101/103/104
- Modbus/RTU and Modbus/TCP
- DNP3
- SPA

DIMENSIONS

- H, W, D without terminal 208 x 257 x 165 mm

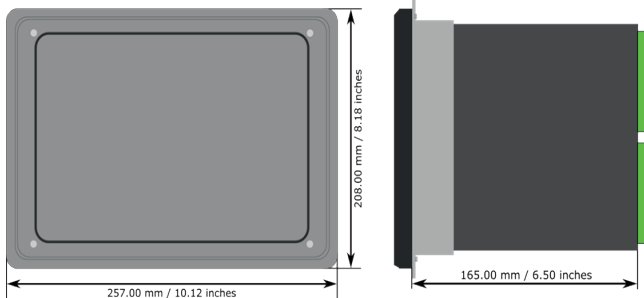

SERVICES



- Studies
- Systems architecture
- FAT, SAT
- Training
- Technical support
- Maintenance

SMART9

SMART9 - Integrated software

Our user friendly SMART9 (Setting, Measurement, Analysis, Recording, Time-saving) configuration software helps you to get the best from NP950 Series relays (connection from RJ45 Ethernet 100Mb front and rear port).

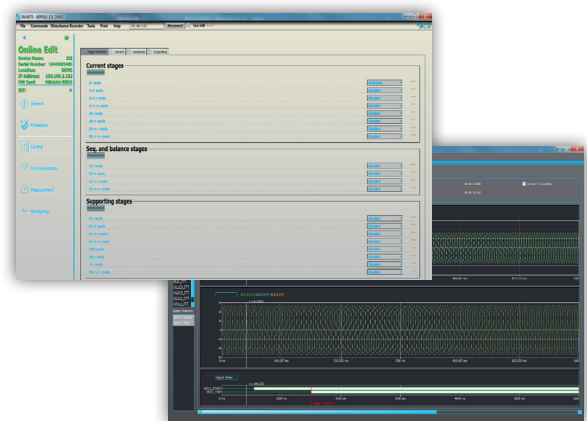

QUALITY SYSTEM

